

FINISH RING				
PART NUMBER	OUTER DIA (IN.)	INNER DIA (IN.)	H1 (IN.)	WEIGHT (lbs.)
46-36F-075	46	36	0.75	N/A
46-36F-100	46	36	1	N/A
46-36F-125	46	36	1.25	N/A
46-36F-150	46	36	1.5	N/A
46-36F-175	46	36	1.75	N/A
46-36F-200	46	36	2	N/A
46-36F-225	46	36	2.25	N/A
46-36F-250	46	36	2.5	N/A
46-36F-400	46	36	4	N/A
46-36F-600	46	36	6	N/A

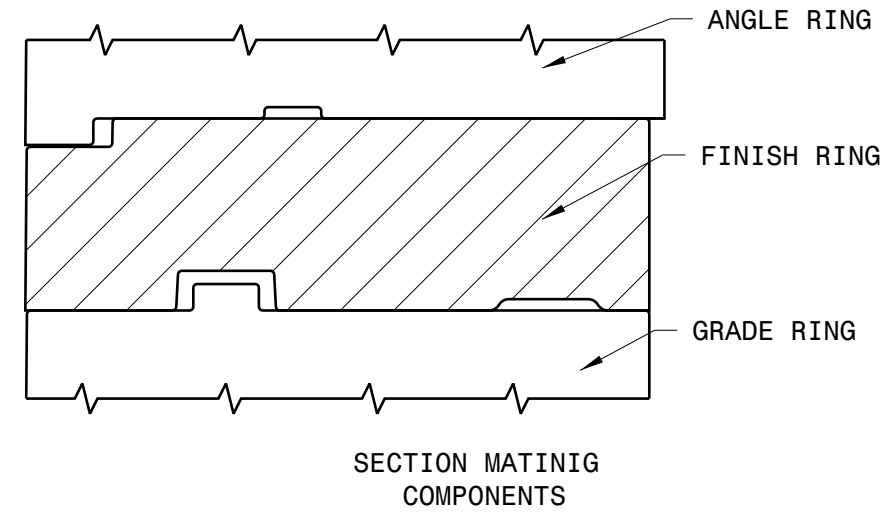

PRO-RING™

MANHOLE ADJUSTMENT SYSTEM

www.PRO-RING.com

46 SERIES FINISH RING

LOAD RATING

HEAVY DUTY

MATERIAL SPECIFICATION

**ARPRO EXPANDED
POLYPROPYLENE BLACK
5000 SERIES
ASTM-D3575**

LAST REVISED

ERN

DATE

08FEB2019

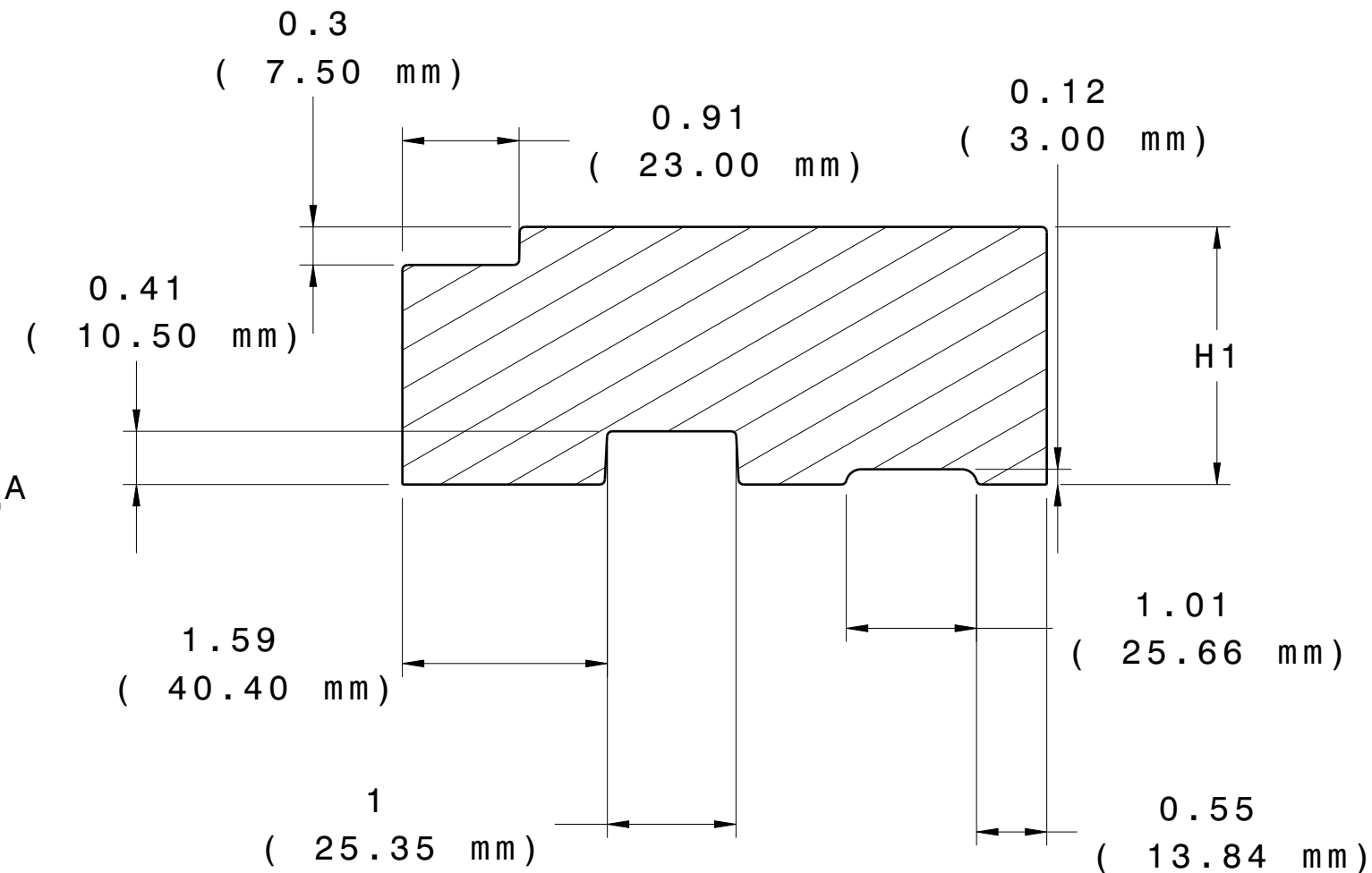
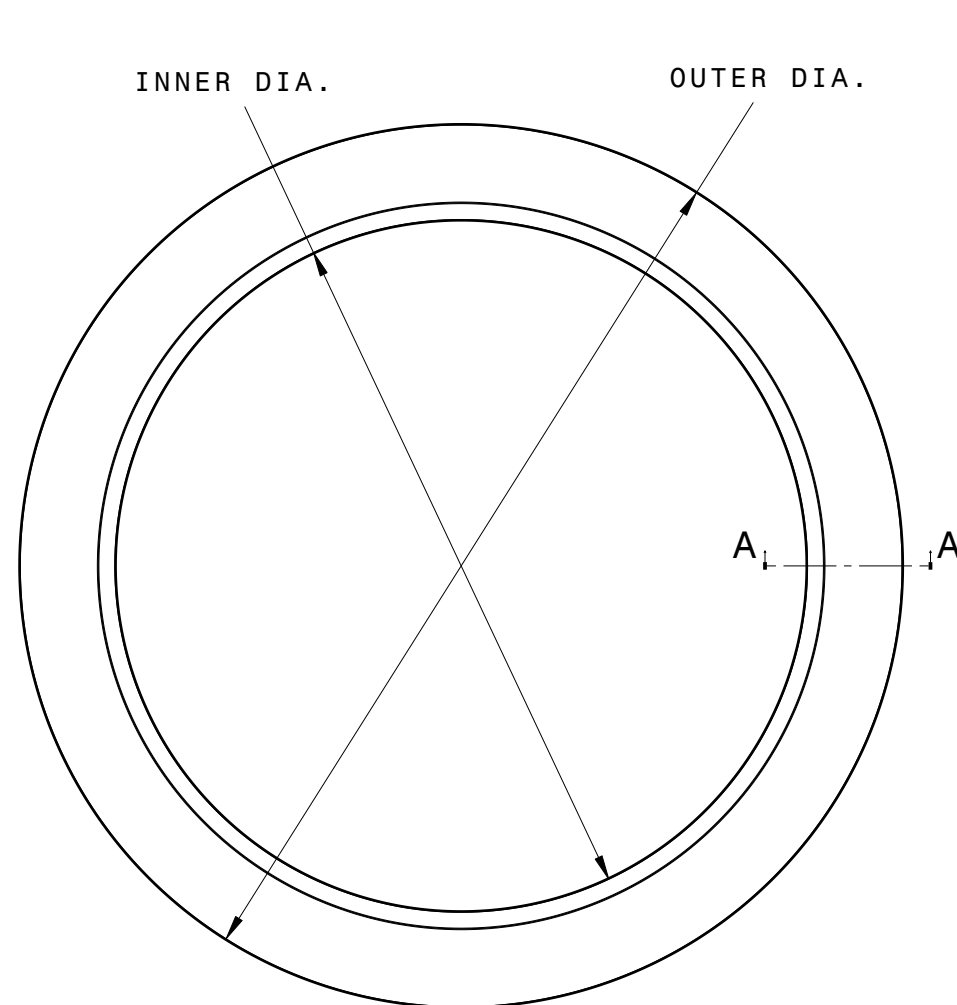

Section cut A-A
Scale: 3:4