

INTERNAL PIPE JOINT SEAL

Stops groundwater infiltration

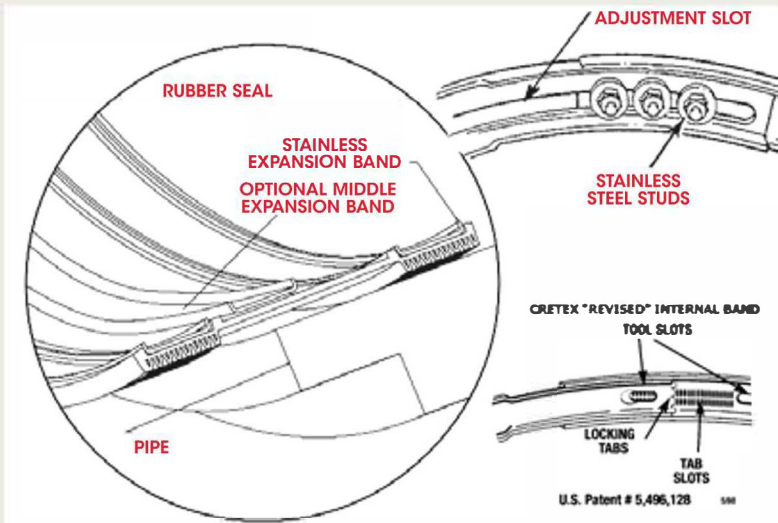

ADVANTAGES:

- Easily installed by a two person crew.
- Conforms to out-of-round shapes.
- Teardrop sealing fins provides superior sealing.
- Provides watertightness, while having the flexibility to allow differential movement caused by ground movement and frost lift.
- Installed mechanically to the inside of existing pipe or manhole.
- Reusable – can be removed and used elsewhere if needed.
- Constructed of high quality materials having a long service life.

THE INTERNAL MANHOLE AND PIPE JOINT SEALS

are watertight compression seals that reduce groundwater infiltration and soil migration through defective joints. Made of high-quality rubber, these seals meet or exceed the physical requirements of ASTM C-923. Designed for new or existing installations, these seals can be installed without excavation on joints with separations up to 3 inches with no offset.

RUBBER SLEEVE Made of a 7-1/2-inch wide high-quality rubber, the Internal Manhole and Pipe Joint Seal meets or exceeds the physical requirements of ASTM C-923 as modified with a 3/16 inch minimum thickness for durability and resistance to puncturing or tearing.

EXPANSION BANDS For seal sizes from 18" diameter to 36" diameter, a one-piece expansion band is used and for 42" and 48" diameter seals, two-piece expansion bands are used. These expansion bands are 1-3/4 inches wide and are fabricated from a high-quality corrosion resistant, 16-gauge stainless steel conforming to the material requirements of ASTM A-240, Type 304, with no welded attachments. The one-piece band is comprised of multiple transverse tab slots and overlapping locking tabs that provides for a 2-1/2-inch diameter range while the two-piece band is comprised of two 8-inch adjustment slots and provides for a 2-inch diameter range. An easy to use mechanical expansion tool quickly expands the bands to compress the rubber sleeve against the manhole or pipe wall. The one-piece bands are locked in place by engagement of the locking tabs while the two-piece bands are locked in place by the tightening of the two sets of three, self-locking stainless steel studs and nuts.

SPECIFICATIONS

GENERAL

When required in the contract document, the Contractor shall provide all labor, equipment and materials to seal manhole or pipe joints subjected to 14 feet or less of head with an internal rubber seal manufactured by Cretex Specialty Products, Waukesha, WI, www.cretexseals.com or pre-approved equal.

PRODUCTS

INTERNAL RUBBER SEAL

Internal rubber seals used for sealing pipe joints shall consist of the following components.

RUBBER SLEEVE

The flexible rubber sleeve shall be extruded from a high-grade rubber compound conforming to the applicable requirements of ASTM C-923, with a minimum 1500-psi tensile strength, maximum 18% compression set, and a hardness (durometer) of 48±5.

The sleeve shall be available in a 7.5 inch width, a minimum thickness of 3/16 inches and shall be capable of expansion when installed of not less than 2 diameter inches. The sleeve shall contain two integrally formed expansion band recesses and multiple sealing fins. The sleeve is designed to span joints with separations of not greater than 3 inches with no offset. Offsets will reduce the allowable span distance.

Any splice used to fabricate the sleeve shall be vulcanized and have a strength such that the sleeve shall withstand a 180 degree bend with no visible separation.

EXPANSION BANDS

The one or two piece expansion bands used to compress the sleeve against the pipe shall be 16 gauge stainless steel conforming to ASTM A-240, Type 304, with a minimum width of 1-3/4 inches and shall have a minimum adjustment range of 2 diameter inches. The expansion mechanisms shall have the capacity to develop the pressures necessary to make a watertight seal. Any fasteners used to lock the bands in their expanded position shall be stainless steel conforming to ASTM F-593 and 594, Type 304.

MIDDLE EXPANSION BAND

A one or two piece middle band is required to prevent excessive ballooning of the sleeve when hydrostatic pressure is or is expected to be greater than 6 feet of head and shall meet the same material requirements as that of the main outer bands.

INSTALLATION

The inside surface of the manhole or pipe extending approximately 5 inches on either side of the joint shall be reasonably smooth, non-porous and free of any lime or other deposits, loose material and excessive voids. Any voids, cracks or porous surfaces shall be repaired with a material recommended by the manufacturer. After the rubber sleeve has been placed in the proper position, the required number of one or two piece stainless steel expansion bands shall be installed in the band recesses and individually tightened as required to provide a watertight seal.

Detailed installation procedures shall be in accordance with the manufacturers instructions.

PHYSICAL PROPERTIES

Tensile Strength	1500 psi
Elongation at break	350% min.
Hardness (Durometer)	48+5
Accelerated oven-aging	max. 15% decrease of tensile, 20% of elongation
Chemical resistance	no weight loss in 1 N of sulfuric or hydrochloric acid
Compression set	18% max. decrease
Water absorption	max. 10% increase by weight
Ozone resistance	rating 0
Low temperature brittle point	No fracture at -40°C.
Tear resistance	200 lb. f/in.
Splice strength	180° bend with no visible separation

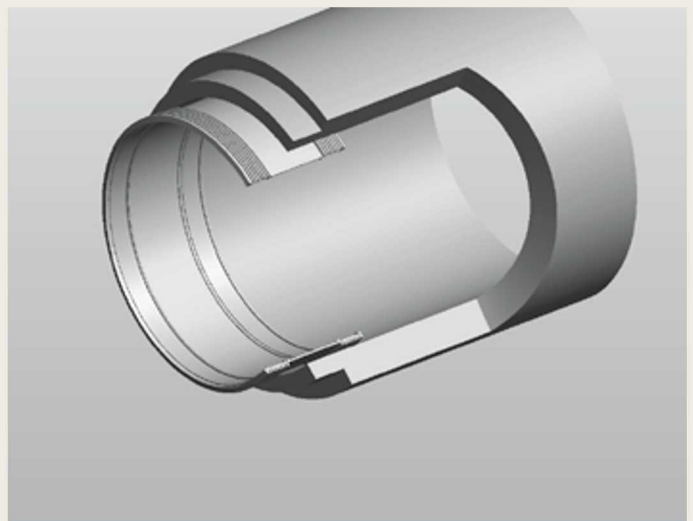

SUGGESTED SPECIFICATION FOR INTERNAL MANHOLE OR PIPE JOINT SEALS

PART 1 GENERAL

1.01 SCOPE

This section includes the materials and procedures required to provide for the internal sealing of joints in Precast Concrete manholes and in most types of pipe, including but not limited to Reinforced Concrete, PVC, HDPE, Fiberglass, Steel or Vitrified Clay. The sealing shall be accomplished via the installation of a mechanical internal joint sealing system. Seals shall only be permitted on joints subjected to not greater than 14 feet of head pressure (approximately 6 psi).

PART 2 PRODUCTS

2.01 INTERNAL JOINT SEAL

Internal joint seals shall consist of a flexible rubber sleeve and stainless steel expansion bands conforming to the following requirements.

- A. Rubber Sleeve – The flexible rubber sleeve shall be molded or extruded from a high grade rubber compound conforming to the applicable material requirements of ASTM C-923 with a minimum 1500 psi tensile strength, maximum 18% compression set and a hardness (durometer) of 48±5.

The sleeve shall have a minimum width of 7.5 inches and a minimum thickness of 3/16 inches. Both end sections of the sleeve shall have an integrally formed expansion band recess and series of sealing fins to facilitate a watertight seal. These sealing fins shall have teardrop holes or air pockets to allow them to conform to minor surface irregularities that may be encountered on the manhole or pipe surfaces. The sleeve is designed to span joints with separations of not greater than 3 inches with no offset. Offsets will reduce the allowable span distance.

- B. Expansion Bands – The expansion bands used to compress the sleeve against pipe or manhole wall shall be formed from a minimum 16 gauge stainless steel conforming to the applicable material requirements of ASTM C-923, Type 304 and shall have a minimum width of 1-3/4 inches. Expansion bands may consist of one or two pieces depending on the inside diameter of the manhole or pipe. To prevent ballooning, a center band shall be used where greater than 6 feet of head pressure (approximately 2.5 psi) is expected.

The mechanism used to expand the bands shall have the capacity to develop the pressure necessary to provide a watertight seal once the bands have been locked into place. Any fasteners used to lock the bands into place after tightening shall be stainless steel conforming to ASTM F-593, Type 304.

- C. Acceptable Manufacturer's
Cretex Specialty Products
Pre-Approved Equal

PART 3 EXECUTION

3.01 INSTALLATION

All work to be performed shall be in strict accordance with the ENGINEER's specifications and recommendations, including installation and application of all products as required and in accordance with the manufacturer's recommended installation and surface preparation instructions. The CONTRACTOR shall be responsible for field measuring each pipe or manhole joint to be sealed. This information is required to determine the proper size of rubber sleeve and the size and number of expansion bands required to complete each installation.

INTERNAL PIPE JOINT SEAL INSTALLATION INSTRUCTIONS FOR 36" AND UNDER DIAMETER

1. Wire brush the surface 5 inches on either side of the leaking joint to remove lime and other deposits. Wipe this area with mortar, filling the cracks and porous surfaces, providing a smooth sealing surface. PREPARATION OF THIS SURFACE IS ABSOLUTELY NECESSARY.
2. Make a series of alignment marks 4 inches away from the joint and install rubber sleeve so it is positioned along alignment marks and centered over the joint.
3. Lubricate and install the first band in the appropriate band recess with the slotted end against the rubber surface. Position the expansion tool as shown below and expand the band until the locking tabs pop into the tightest slots possible. To ensure proper tightness, stop expanding and let the seal "relax" for 30 to 60 seconds and then try to tighten again to the next set of slots. Once the band is fully tightened, loosen the expansion tool slowly until the tabs are fully engaged in the slots, and then continue to loosen and remove the tool.
4. Lubricate the second band and install it in the other band recess, attach the tool and expand as before, keeping the bands parallel. The seal may be adjusted up or down as required for minimum or maximum chimney coverage or if excessive sleeve expansion is required.
5. Repeat band installation procedure for the middle band if required.
6. Check the top and bottom edges of the installed sleeve to insure that they have been properly compressed against the surfaces.

NOTES:

1. A smooth, non-porous sealing surface must be prepared.
2. Do not use if water pressure head is expected to exceed 14 feet.

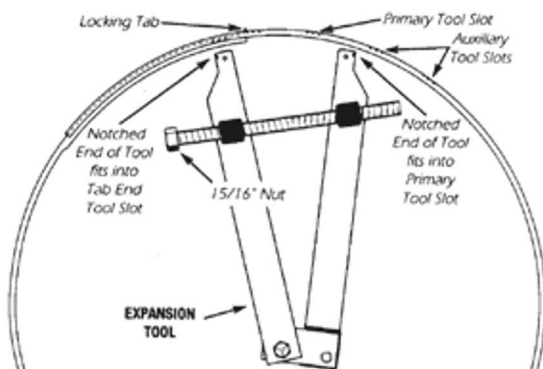

INTERNAL PIPE JOINT SEAL INSTALLATION INSTRUCTIONS FOR 42" AND 48" DIAMETER

1. Wire brush the surface 5 inches on either side of the leaking joint to remove lime and other deposits. Wipe this area with mortar, filling the cracks and porous surface, providing a smooth sealing surface. PREPARATION OF THIS SURFACE IS ABSOLUTELY NECESSARY.
2. Make a series of alignment marks 4 inches away from the joint and install rubber sleeve so it is positioned along alignment marks and centered over the joint.
3. LUBRICATE all bands and assemble by overlapping 2 band ends such that the studs of each band lay behind and extend through the other band's adjustment slot.
4. Position bands in the band recess of the sleeve, center studs in each adjustment slot and tighten lock nuts (3) on one side of band only. To generate the force necessary to provide a watertight seal, bands must be expanded at both adjustment slots.
5. Place the installation tool in the opposite adjustment slot, as shown below, and expand the band until tight. Check to insure that the sleeve is tight against the surface around its entire perimeter, check tool tightness and tighten the 3 lock nuts.
6. Remove tool and place in first adjustment slot. Expand tool, as needed, to prevent slippage while lock nuts are loosened. Expand, as necessary, to provide a watertight seal. Securely tighten the 3 lock nuts.
7. Repeat band installation procedure for each band.
8. Repeat band installation procedure for the middle band if required.

NOTES:

1. A smooth, non-porous sealing surface must be prepared.
2. Do not use if water pressure head is expected to exceed 14 feet.

